

Standard Operating Procedure <b>Otosopes and Ophthalmoscopes</b>		
SOP Number: <u>SOP-OO-01.1</u>	Category: <u>Lab Process</u>	
Supersedes: <u>SOP-OO-01</u>	Effective Date: <u>December 1, 2017</u>	
	Pages	<u>7</u>
Subject: <b>Otosopes and Ophthalmoscopes</b>		

Prepared By: <u>Lisa McAvoy</u>	<u>28/Nov/17</u> dd/mmm/yy
Approved By: <u>Veronica Harris-McAllister</u>	<u>30/Nov/17</u> dd/mmm/yy

## 1.0 POLICY

This standard operating procedure (SOP) describes the correct procedures when using the Welch Allyn MacroView™ Otoscope with throat illuminator and coaxial Ophthalmoscope for clinical research, including clinical trials, in the W.J. Henderson Centre for Patient-Oriented Research (WJHCPOR). The otoscopes and ophthalmoscopes are intended to be used by qualified and trained users of the WJHCPOR for eye, ear, and throat examination of research participants. Only trained medical professionals can provide diagnosis of any clinical findings presented by research participants upon examination.

## 2.0 PURPOSE

To ensure all users of the WJHCPOR use correct procedures when using the otoscopes and ophthalmoscopes for eye, ear and throat examination of research participants.

## 3.0 RESPONSIBILITY

Users are responsible for:

- Attending orientation and training on the proper use of the otoscopes and ophthalmoscopes.
- Following the procedures listed in this SOP. **NOTE:** If at any time users are unsure how to operate the otoscopes and ophthalmoscopes safely, please refer to the instructional manuals and/or ask the designated KGHR staff member for assistance.
- Reporting any damage to the otoscopes and ophthalmoscopes to the designated KGHR staff member immediately so equipment repairs can be made.

- Cleaning the otoscopes and ophthalmoscopes after each use and between research participants.

KGHRI is responsible for:

- Ensuring all otoscopes and ophthalmoscopes are in good repair and labelled with appropriate contact information for maintenance and repair.
- Training new users in safe usage and maintenance of the otoscopes and ophthalmoscopes, documenting the training of all users, and supervising use when necessary.
- Ensuring instructional manuals (see Appendix A and Appendix B) are readily available to all users, if required.
- Ensuring that all the regular and periodic maintenance required for the otoscopes and ophthalmoscopes is carried out and recorded in the Maintenance Log. The designated KGHRI staff member will contact Kingston Health Sciences Centre's (KHSC) Clinical Engineering Department when regular maintenance inspection and repairs are required.
- Ensuring the records of repair are kept and available for inspection.
- Providing appropriate cleaning supplies to users of the WJHCPOR.
- Charging the otoscopes and ophthalmoscopes.

## 4.0 PROCEDURE

### Using the Otoscope for Ear Examinations

- The otoscope is intended to allow users of the WJHCPOR the ability to perform an examination of the external ear, ear canal and tympanic membrane under magnification.
- Using the otoscope head:
  - Align the cutouts in the otoscope head base with the 3.5-volt power source lug.
  - Push down slightly and turn 90° clockwise. To remove, reverse the procedure. See Figure 1 below.
  - Align one of the Welch Allyn disposable/single-use specula tips (adult tip 4.25 mm or paediatric tip 2.75 mm) onto the otoscope using a disposable glove. Twist the specula clockwise until it clicks into the locked position. See Figure 1 below. To remove the specula tip, turn the TipGrip or twist the specula counterclockwise. The specula tips are disposable/single-use and should be tossed into the regular waste bin/container after use. A new specula tip should be used for each research participant.

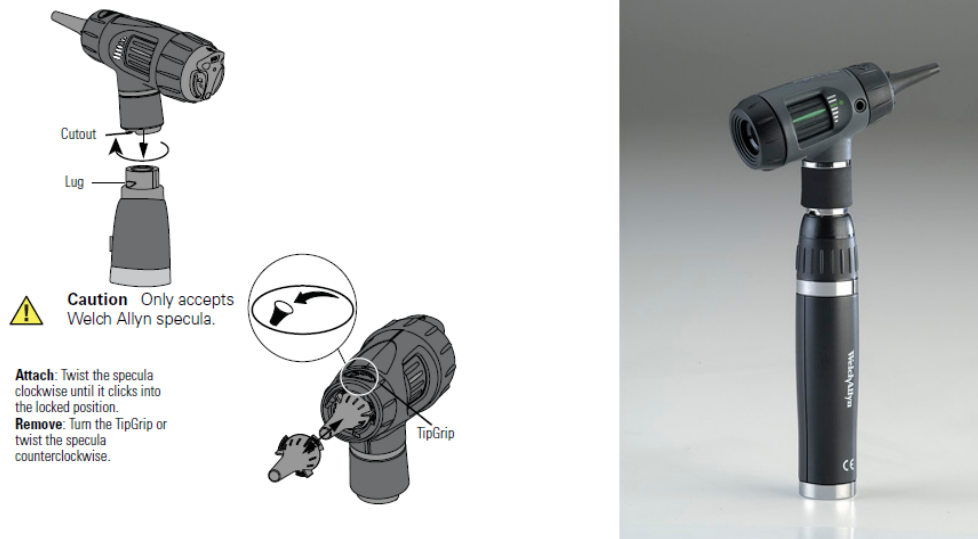

Figure 1: Using the Otoscope

- To turn the otoscope on, push the green button on the 3.5-volt power source lug and rotate the wheel clockwise. The otoscope is on when the light is on. To turn the otoscope off, rotate the wheel counterclockwise until you hear the green button click back into place. The light will be off when the otoscope is off.
- To focus align the green line to the green dot and rotate either the inner or outer wheel to fine tune the image of the eye. See Figure 2 below.

**Default Position:** align the green line to the green dot.

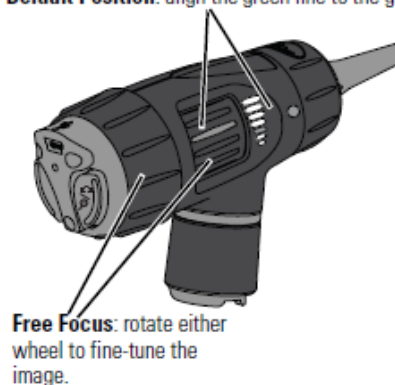

Figure 2: Using the Focus on the Otoscope

- Perform the ear examination.

## Using the Ophthalmoscope for Eye Examinations

- The ophthalmoscope is intended to allow users of the WJHCPOR the ability to perform an examination of the fundus and other ocular structures (cornea, iris, pupil, lens) of the eye under magnification.
- Using the ophthalmoscope head:
  - Align the cutouts in the ophthalmoscope head base with the 3.5-volt power source lug. See Figure 3 below.
  - Push down slightly and turn 90° clockwise. To remove, reverse the procedure.



Figure 3: Using the Ophthalmoscope

- To turn the ophthalmoscope on, push the green button on the 3.5-volt power source lug and rotate the wheel clockwise. The ophthalmoscope is on when the light is on. To turn the ophthalmoscope off, rotate the wheel counterclockwise until you hear the green button click back into place. The light will be off when the ophthalmoscope is off.
- Choose the appropriate aperture. There is a wide range of practical apertures to select from: micro spot, small spot, large spot, fixation, slit, and cobalt blue filter. A red-free filter (green dot) is also available and can be used in conjunction with any apertures. When the switch is positioned to the right (circle with crosshairs inside) the crossed linear polarizing filter will be in place and can be used in conjunction with any apertures. See Figure 3 above.
- Perform the eye examination.

## Using the Otoscope for Throat Examinations

- The base of the otoscope can be transformed into a throat illuminator.
- Using the throat illuminator head:
  - Grasp the otoscope section with your left hand.
  - Grasp the throat illuminator collar (under the silver ring).
  - Hold the throat illuminator collar stationary and twist the otoscope section counterclockwise until the otoscope head is removed. See Figure 4 below.
  - In order for the throat illuminator to work it must be attached to the 3.5-volt power source lug.
  - To turn the throat illuminator on, push the green button on the 3.5-volt power source lug and rotate the wheel clockwise. The throat illuminator is on when the light is on. To turn the throat illuminator off, rotate the wheel counterclockwise until you hear the green button click back into place. The light will be off when the throat illuminator is off.
  - To replace the otoscope section, align the otoscope section with the top of the throat illuminator and turn clockwise.

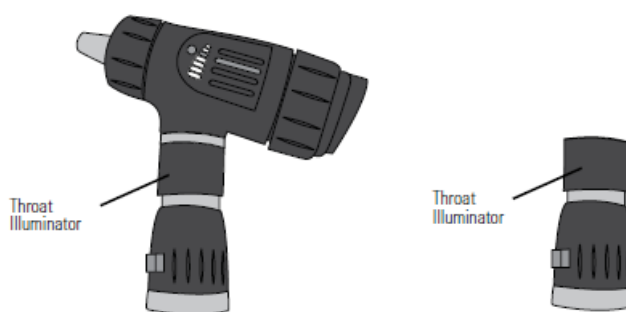

Figure 4: Using the Throat Illuminator

- Perform the throat examination.

## Cleaning the Otoscopes and Ophthalmoscopes

- After each research participant use, users **MUST** wipe down otoscopes and ophthalmoscopes with a dry cloth. **DO NOT** apply alcohol, chemicals, cleaning products or water as it will damage the otoscopes and ophthalmoscopes. Ensure the otoscopes and ophthalmoscopes are off before cleaning.

### Charging the Otosopes and Ophthalmoscopes

- Attach the 3.5-volt power source lug to the AC charging module. See Figure 5 below.
- Push the black button on the wall charger unit and pull the case of the AC charging module towards the 3.5-volt power source lug. This will retract the AC prongs. See Figure 6.
- Plug the unit into an electrical wall power source to allow the unit to charge. Charge for 12 continuous hours.
- Once fully charged the 3.5-volt power source lug will last for two (2) continuous hours before it needs to be charged again.



Figure 5: Otoscope and Ophthalmoscopes Parts



Figure 6: Charging the Otoscope and Ophthalmoscopes

## 5.0 CONTACTS

### **Research Administration Facilitator (Designated KGHRI Staff Member):**

Lisa McAvoy  
Kingston General Health Research Institute  
W.J. Henderson Centre for Patient Oriented Research  
Connell 4, Kingston Health Science Centre (KGH Campus)  
Kingston, Ontario K7L 2V7  
613-549-6666 ext. 3344  
[mcavoye1@kgh.kari.net](mailto:mcavoye1@kgh.kari.net)

### **Director, Health Sciences Research:**

Veronica Harris-McAllister  
Kingston General Health Research Institute  
W.J. Henderson Centre for Patient Oriented Research  
Connell 4, Kingston Health Science Centre (KGH Campus)  
Kingston, Ontario K7L 2V7  
613-549-6666 ext. 3653  
[harrismv@kgh.kari.net](mailto:harrismv@kgh.kari.net)

## 6.0 SOP HISTORY

SOP Number	Date Issued	Summary of Revisions
SOP-OO-01	01-DEC-2017	Original version.
SOP-OO-01.1	01-FEB-2018	Otoscope instruction manual added to policy. New appendix added to policy as "Appendix A". Ophthalmoscope instruction manual added to policy. New appendix added to policy as "Appendix B".